

Easypack
Easypack®



www.easypack.net

Simple and effective

Customers are provided with a high output converting machine on economical monthly rental, which is loaded with a roll of paper having two or three layers. As this passes through the machine it is shaped and formed into a continuous cushion which is cut off to the selected length.

Multilayered paper cushions are strong, flexible, easy to handle and provide excellent protection for all types of product. Cushions can be formed into shock absorbing buffers to block and brace goods and hold them firmly in place.

Cushions are clean, simple to use and are favoured by recipients as they are easy to unpack and are readily disposable.

There are massive savings on storage space as rolls of 2 ply paper are converted to 60 times their original volume right at the point of packing.



Eco friendly

- All Easypack paper is produced from 100% recycled cardboard and paper containing no virgin fibre
- Can be re-used or recycled and is biodegradable
- Completely free of oil based products
- Total fill is not necessary - airspace is left within the box
- Packaging is produced on demand, reducing bulk transport cost
- Resilient paper packaging means that smaller boxes can be used which in turn leads to less fill
- High machine output speeds up the packing process, reducing labour and packing time

Packing solutions

Machines are supplied in horizontal or vertical configurations or built into space saving work benches. Our engineers can also design special mounting frames to integrate with existing conveyors or packing lines.

An optional hand held programmer is available so that exactly the right amount of void fill can be quickly selected to suit any combination of product and box size.



Vertical machine



Single bench



Superior protection

Lightweight paper cushions are the perfect packaging material, providing complete product protection to avoid damage to goods in transit. They can be used for all round protection or formed into coils to support heavy items. Easypack paper is supplied in different grades to suit all types of product and is sold in natural brown or clean white colour.

Rapid paper change for easy loading

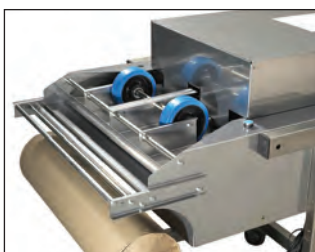

Slide the roll onto the carrier



Separate the ends



Feed into the drive wheels



Press the load button

TECHNICAL DATA

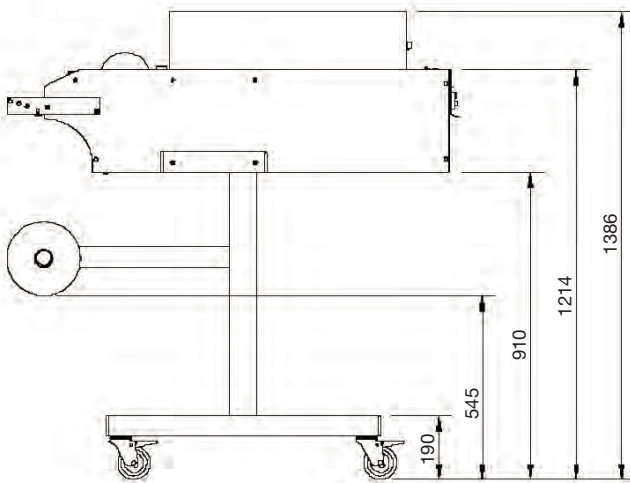
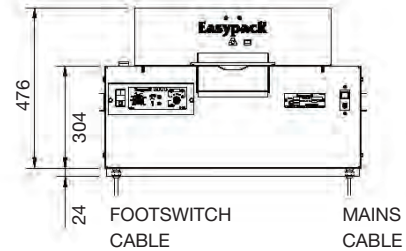
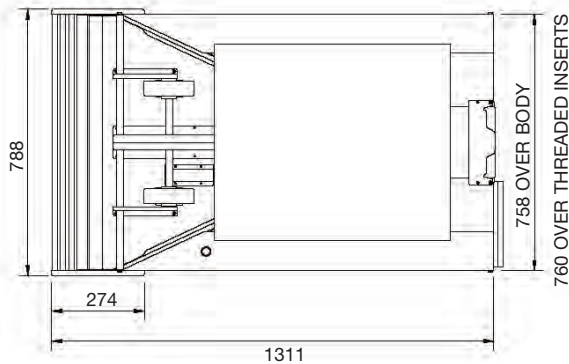

MACHINE IN RAISED HEIGHT POSITION IN FRAME

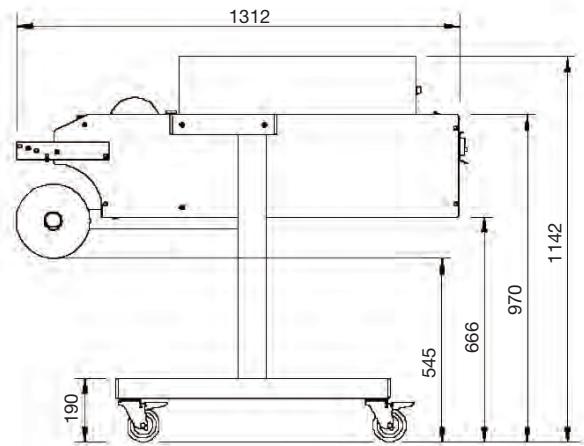

MACHINE IN NORMAL HEIGHT POSITION IN FRAME

FOOT PEDAL SUPPLIED WITH EACH MACHINE
ALL MEASUREMENTS IN mm UNLESS OTHERWISE STATED

SPECIFICATION

| | |
|---------------------------------------|--------------------|
| Pallet quantity | 20 rolls |
| Machine Weight (standard, with stand) | 147 kg (approx.) |
| Roll Length (standard 2 ply roll) | 225 m |
| Cushion Width | 190 mm |
| Output Volume (standard 2 ply roll) | 2.1 m ³ |
| Average Output Speed | 24.6 m per min |
| Ideal Usage | Continuous |
| Voltage | 220V / 240V |
| Max Power Input | 4A |



Each standard roll produces up to 2.1 cubic metres of void fill

E&OE

UNIT 1 THE io CENTRE
ARLINGTON BUSINESS PARK
STEVENAGE HERTS SG12BD

T: +44 (0)845 838 0168
F: +44 (0)845 838 0160
e: info@easypack.net

www.easypack.net